

CBCS SCHEME

USN

--	--	--	--	--	--	--	--	--	--

15ME64

Sixth Semester B.E. Degree Examination, Feb./Mar. 2022 Design of Machine Elements - II

Time: 3 hrs.

Max. Marks: 80

- Note: 1. Answer any FIVE full questions, choosing ONE full question from each module.
2. Use of design data hand book is permitted.
3. Missing data, if any, assume suitably.*

Module-1

- 1 a. Derive an expression for normal stresses due to bending at the extreme fibers on the cross section of a curved machine member. (06 Marks)
b. Compute the combined stresses at the inner and outer fibers in the critical cross section of a crane hook which is required to lift loads upto 25 kN. The hook has trapezoidal cross section with parallel sides 60 mm and 30 mm, the distance between them being 90 mm. The inner radius of the hook is 100 mm. The load line is nearer to the inner surface of the hook by 25 mm than the centre of the curvature at the critical section. What will be the stresses at the inner and outer fiber if the beam is treated as a straight beam for the given load? (10 Marks)

OR

- 2 A 400 mm outside dia \times 200 mm inside diameter steel hub is to have a shrink fit on a shaft of diameter 200 mm. The tangential stress is to be limited to 90 MPa. The hub length is 270 mm. Modulus of elasticity is 206 GPa. Poisson ratio is 0.3.
(i) Find and sketch the resulting stress distribution.
(ii) The original diameters before shrink fit.
(iii) The axial force necessary to assemble the hub taking coefficient of friction as 0.1.
(iv) The power that can be transmitted by this joint at 1200 rpm. (16 Marks)

Module-2

- 3 a. A V-belt drive is to transmit 18.5 KW from a 250 mm pitch diameter pulley operating at 1800 rpm to a 900 mm flat pulley. The centre distance between the input and output shafts is 1m. The groove angle is 40° and the coefficient of friction is 0.2 for both pulley belt combination. The cross section of the belt is 38 mm wide at the top, 19 mm wide at the bottom and 25 mm deep. Each belt weighs 11 kN/m^3 and the allowable tension per belt is 900 N. How many belts are required? (08 Marks)
b. Select a suitable roller chain to transmit 6 KW power from an electric motor to an air compressor. The speed of motor and compressor are 900 rpm and 375 rpm respectively. The approximate distance between the sprockets is 600 mm. Take a factor of safety based on breaking load as 6. (08 Marks)

OR

- 4 a. A 25 mm 6×37 steel wire rope is used in a mine of 80 m deep. The velocity of the cage is 2 m/sec and the time required to accelerate the cage to the desired velocity is 10secs. The diameter of the drum is 1.25 m. Determine the safe load that the hoist can handle by assuming a factor of safety as 8. Neglect the impact load on the rope. (06 Marks)
b. Derive an expression for the shear stress induced in a helical compression spring with usual notations. (04 Marks)
c. Design a helical compression spring to sustain a load of 1.5 kN with an associated deflection of 40 mm and shear stress in yield as 900 MPa. (06 Marks)

Module-3

- 5 It is required to transmit 15 KW power from a shaft running at 1200 rpm to a parallel shaft with speed reduction of 3. The centre distance of shafts is to be 300 mm. The material used for pinion is steel ($\sigma_d = 200$ MPa) and for gear is cast iron ($\sigma_d = 140$ MPa). Service factor is 1.25 and tooth profile is 20° full depth involute. Design the spur gear and check the design for dynamic load and wear. (16 Marks)

OR

- 6 A pair of helical gears are to transmit 16 KW. The teeth are 20° stub in diametral plane and have a helix angle of 45° . The pinion runs at 10,000 rpm and has 80 mm pitch diameter. The gear has 320 mm pitch diameter. If the gears are made of cast steel having allowable static strength of 100 MPa, determine module and face width from static strength considerations and check the gears for wear given $\sigma_{es} = 618$ MPa. (16 Marks)

Module-4

- 7 a. 75 KW power at 3000 rpm is to be transmitted by a multiplate friction clutch. The plates have friction surfaces of steel and phosphor bronze alternatively and run in oil. Design the clutch for 25% over load. (08 Marks)
- b. A hardened steel worm rotating at 1200 rpm transmits power to a phosphor bronze gear ($\sigma_0 = 55$ MN/m²) with a transmission ratio of 15 to 1. The center distance is 200 mm. Determine the power input rating from the stand point of strength. (08 Marks)

OR

- 8 Fig.Q8 shows a simple band brake which is applied to a shaft carrying a flywheel (a rotating drum) of mass 350 kg and of radius of gyration 400 mm. The flywheel rotates at 250 rev/min. The brake drum diameter is 260 mm and coefficient of friction is 0.20. The angle of lap of the band on the drum is 210° . If the braking torque is 39 Nm, find :
- The force applied at the lever end.
 - The number of turns of the flywheel before it comes to rest.
 - Time taken by the flywheel to come to rest.

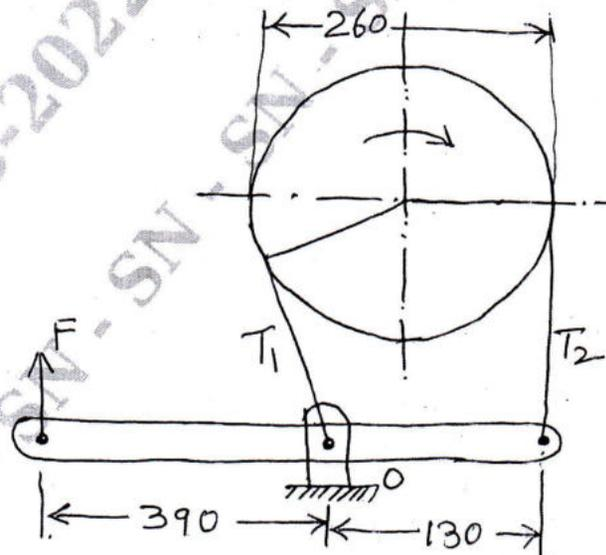

Fig.Q8

(16 Marks)

Module-5

- 9 a. Derive Petroff's equation for coefficient of friction in journal bearing. (08 Marks)
- b. A full journal bearing of 50 mm diameter and 100 mm long is to carry a radial load of 6 kN. The speed of the journal is 600 rpm and the diametral clearance is 0.05 mm. The bearing is lubricated with SAE 30 oil and the operating temperature of oil is 70°C. The inlet temperature of oil is 40°C. Calculate the power loss due to friction and the flow of oil required to dissipate the heat generated during the operation. Use McKee's equation. (08 Marks)
- OR**
- 10 a. Enumerate the advantages and disadvantages of rolling contact bearings. (06 Marks)
- b. Select a single row deep groove ball bearing to carry a radial load of 4 kN and a thrust load of 5 kN operating at a speed of 1200 rpm, for an average life of 15 years at 10 hours per day. Assume there are 250 working days per year. The loads are steady and the outer ring rotates. (10 Marks)
